

1

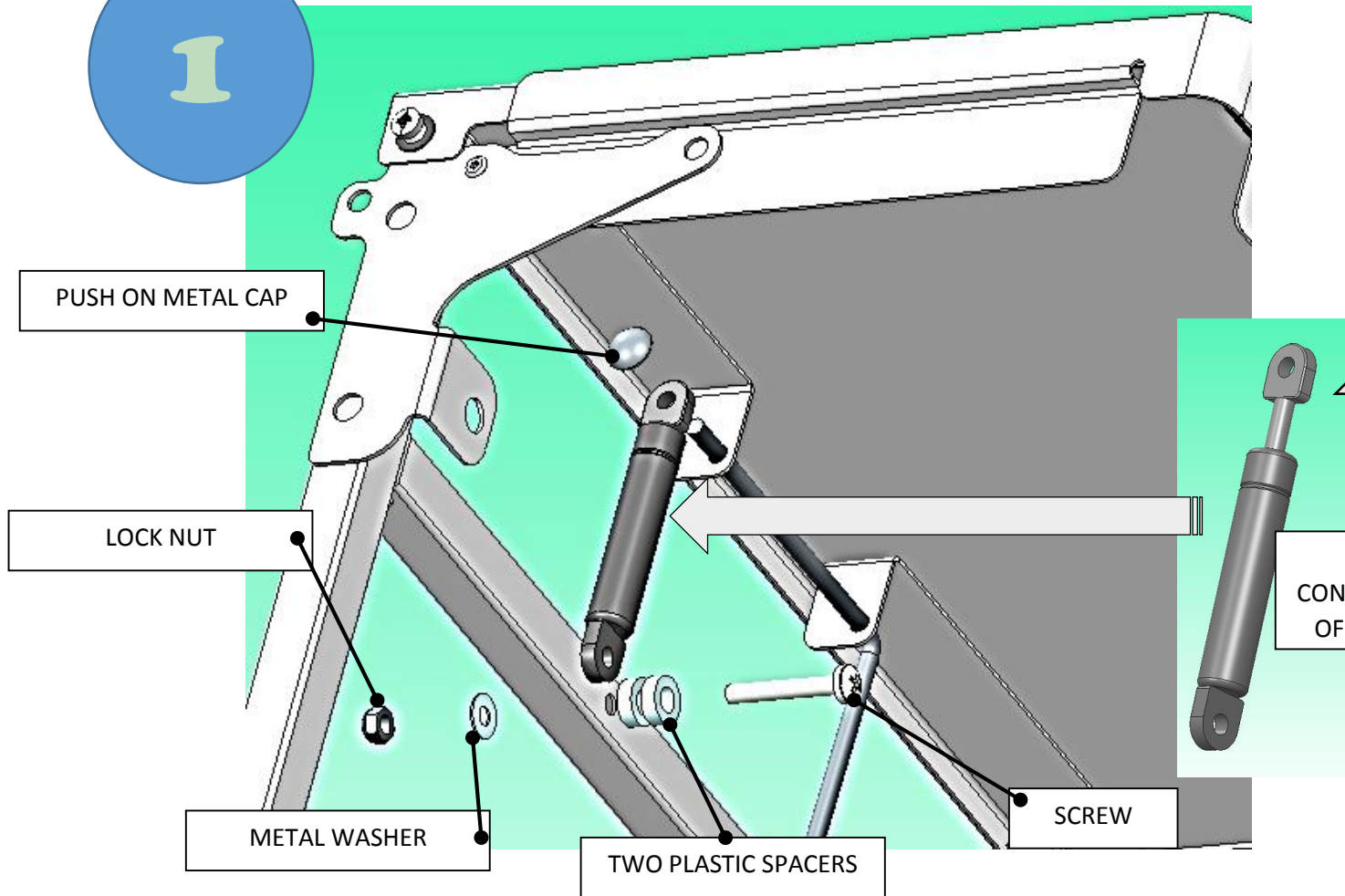

2

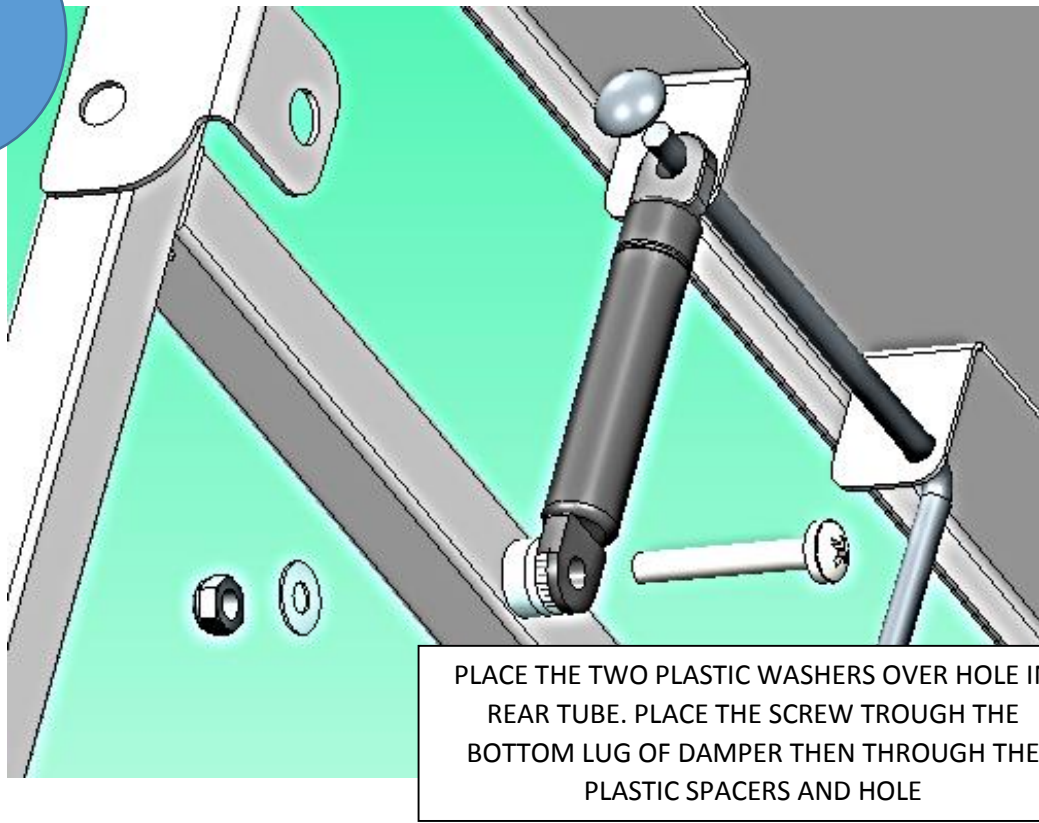

3

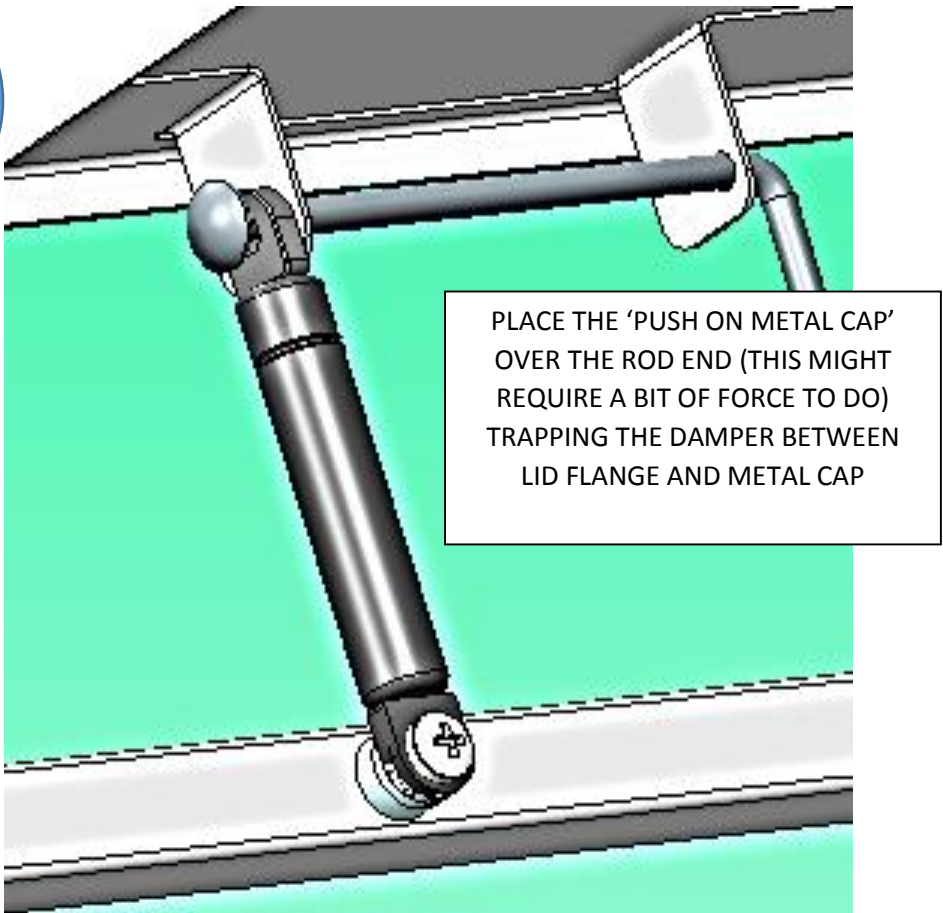

4

PLACE THE METAL WASHER ON TO THE PROTRUDING SCREW END THEN TIGHTEN UP THE LOCK NUT.
PLEASE DON'T OVER TIGHTEN THE NUT ALLOW A BIT OF MOVEMENT FOR THE DAMPER

